

D=diameter d=bore h1=depth without cross cutting unit (A,B,D,F.)  
 S=thickness h2=depth with cross cutting unit (C,E,G.)

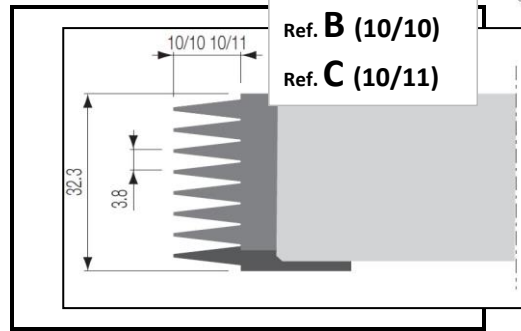

Ref.	D	S	d	h1	h2	Z	HSS knives Cutter	HW knives Cutter
Ref. A	160	25.6	30-60	4/4	-	2+2	FRC84.A1602564S	-
Ref. A	250	25.6	30-60	4/4	-	3+3	FRC84.A2502566S	-

Ref.	D	S	d	h1	h2	Z	HSS knives Cutter	HW knives Cutter
Ref. B	160	30.4	30-60	10/10	-	2+2	FRC84.B1603044S	FRC84.B1603044W
Ref. B	160	30.4	30-60	10/10	-	3+3	FRC84.B1603046S	FRC84.B1603046W
Ref. B	250	30.4	30-60	10/10	-	3+3	FRC84.B2503046S	FRC84.B2503046W
Ref. B	250	30.4	30-60	10/10	-	4+4	FRC84.B2503048S	FRC84.B2503048W
Ref. B	250	30.4	30-60	10/10	-	6+6	FRC84.B2503049S	FRC84.B2503049W
Ref. C	160	30.4	30-60	-	10/11	2+2	FRC84.C1603044S	FRC84.C1603044W
Ref. C	160	30.4	30-60	-	10/11	3+3	FRC84.C1603046S	FRC84.C1603046W
Ref. C	250	30.4	30-60	-	10/11	3+3	FRC84.C2503046S	FRC84.C2503046W
Ref. C	250	30.4	30-60	-	10/11	4+4	FRC84.C2503048S	FRC84.C2503048W
Ref. C	250	30.4	30-60	-	10/11	6+6	FRC84.C2503049S	FRC84.C2503049W

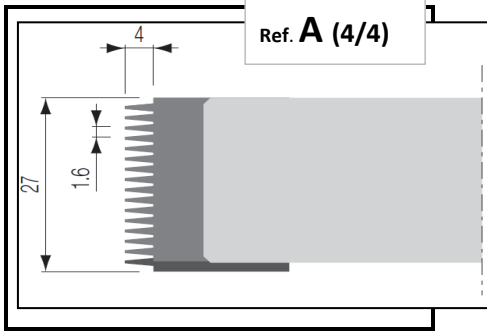
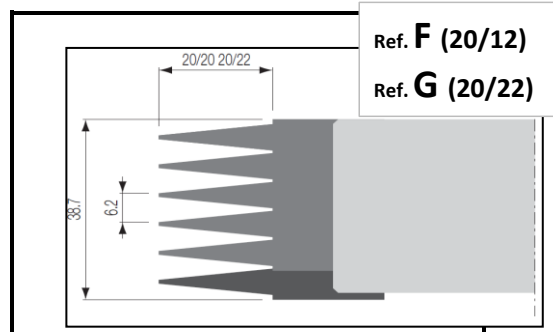
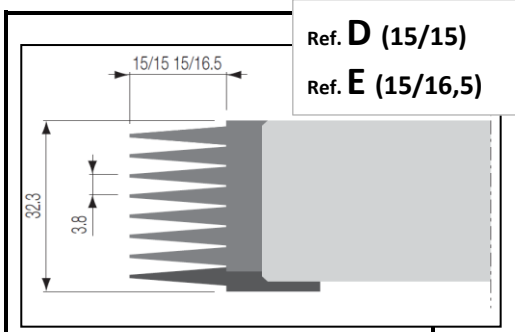

Ref.	D	S	d	h1	h2	Z	HSS knives Cutter	HW knives Cutter
Ref. D	170	30.4	30-60	15/15	-	2+2	FRC84.D1703044S	-
Ref. D	170	30.4	30-60	15/15	-	3+3	FRC84.D1703046S	-
Ref. D	260	30.4	30-60	15/15	-	3+3	FRC84.D2603046S	-
Ref. D	260	30.4	30-60	15/15	-	4+4	FRC84.D2603048S	-
Ref. D	260	30.4	30-60	15/15	-	6+6	FRC84.D2603049S	-
Ref. E	170	30.4	30-60	-	15/16.5	2+2	FRC84.E1703044S	-
Ref. E	170	30.4	30-60	-	15/16.5	3+3	FRC84.E1703046S	-
Ref. E	260	30.4	30-60	-	15/16.5	3+3	FRC84.E2603046S	-
Ref. E	260	30.4	30-60	-	15/16.5	4+4	FRC84.E2603048S	-
Ref. E	260	30.4	30-60	-	15/16.5	6+6	FRC84.E2603049S	-

Ref.	D	S	d	h1	h2	Z	HSS knives Cutter	HW knives Cutter
Ref. F	180	37.2	30-60	20/20	-	2+2	FRC84.F1803724S	-
Ref. F	180	37.2	30-60	20/20	-	3+3	FRC84.F1803726S	-
Ref. F	260	37.2	30-60	20/20	-	3+3	FRC84.F2603726S	-
Ref. F	260	37.2	30-60	20/20	-	4+4	FRC84.F2603728S	-
Ref. F	260	37.2	30-60	20/20	-	6+6	FRC84.F2603729S	-
Ref. G	180	37.2	30-60	-	20/22	2+2	FRC84.G1803724S	-
Ref. G	180	37.2	30-60	-	20/22	3+3	FRC84.G1803726S	-
Ref. G	260	37.2	30-60	-	20/22	3+3	FRC84.G2603726S	-
Ref. G	260	37.2	30-60	-	20/22	4+4	FRC84.G2603728S	-
Ref. G	260	37.2	30-60	-	20/22	6+6	FRC84.G2603729S	-

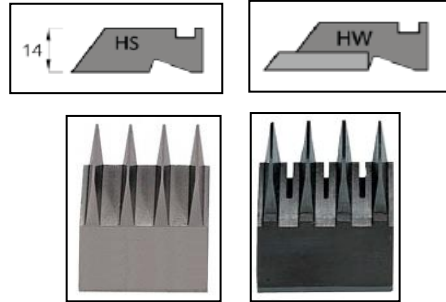
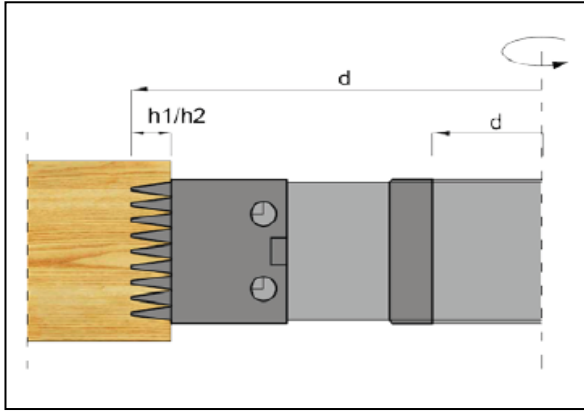

Ref.	-	-	Knife type	Length	Dim.	Pitch	HSS knife	HW knife
Ref. A	-	-	HSS Knife	4/4	25.4x33x14	1.6	FRC84.RA00001HS	-
Ref. B	-	-	HSS/HW Knife	10/10	28.4x38.5x14	3.8	FRC84.RB00002HS	FRC84.RB00002HW
Ref. C	-	-	HSS/HW Knife	10/11	28.4x38.5x14	3.8	FRC84.RC00003HS	FRC84.RC00003HW
Ref. D	-	-	HSS Knife	15/15	28.4x43.5x14	3.8	FRC84.RD00004HS	-
Ref. E	-	-	HSS Knife	15/16.5	28.4x43.5x14	3.8	FRC84.RE00005HS	-
Ref. F	-	-	HSS Knife	20/20	32.5x48x14	6.2	FRC84.RF00006HS	-
Ref. G	-	-	HSS Knife	20/22	32.5x48.5x14	6.2	FRC84.RG00007HS	-

S=wood thickness

SP=cutter thickness

S	Cutters q-ty	D max	SP	Ref.
25.2	1	160(250)	27	<b>A</b> 4/4 Pitch 1,6mm
50.8	2	160(250)	52.6	
76.4	3	160(250)	78.2	
102	4	160(250)	103.8	
127.6	5	160(250)	129.4	
153.2	6	160(250)	155	
S	Cutters q-ty	D max	SP	Ref.
29.8	1	160(250)	32.2	<b>B</b> 10/10 <b>C</b> 10/11 Pitch 3,8mm
60.2	2	160(250)	62.6	
90.6	3	160(250)	93	
121	4	160(250)	123.4	
151.4	5	160(250)	153.8	
181.8	6	160(250)	184.2	
212.2	7	160(250)	214.6	
S	Cutters q-ty	D max	SP	Ref.
29.8	1	170(260)	32.2	<b>D</b> 15/15 <b>E</b> 15/16,5 Pitch 3,8mm
60.2	2	170(260)	62.6	
90.6	3	170(260)	93	
121	4	170(260)	123.4	
151.4	5	170(260)	153.8	
181.8	6	170(260)	184.2	
212.2	7	170(260)	214.6	
242.6	8	170(260)	245	
273	9	170(260)	275.4	
303.4	10	170(260)	305.8	
S	Cutters q-ty	D max	SP	Ref.
36.3	1	180(260)	38.7	<b>F</b> 20/20 <b>G</b> 20/22 Pitch 6,2mm
73.5	2	180(260)	75.9	
110.7	3	180(260)	113.1	
147.9	4	180(260)	150.3	
185.1	5	180(260)	187.5	
222.3	6	180(260)	224.7	
259.5	7	180(260)	261.9	
296.7	8	180(260)	299.1	
333.9	9	180(260)	336.3	

